



# MICAz

## WIRELESS MEASUREMENT SYSTEM

- 2.4 GHz IEEE 802.15.4, Tiny Wireless Measurement System
- Designed Specifically for Deeply Embedded Sensor Networks
- 250 kbps, High Data Rate Radio
- Wireless Communications with Every Node as Router Capability
- Expansion Connector for Light, Temperature, RH, Barometric Pressure, Acceleration/Seismic, Acoustic, Magnetic and other ACEINNA Sensor Boards

### Applications

- Indoor Building Monitoring and Security
- Acoustic, Video, Vibration and Other High Speed Sensor Data
- Large Scale Sensor Networks (1000+ Points)

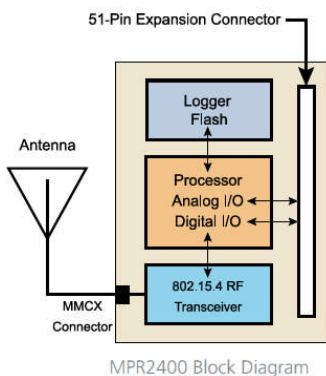

### MICAz

The MICAz is a 2.4 GHz Mote module used for enabling low-power, wireless sensor networks.

#### Product features include:

- IEEE 802.15.4 compliant RF transceiver
- 2.4 to 2.48 GHz, a globally compatible ISM band
- Direct sequence spread spectrum radio which is resistant to RF interference and provides inherent data security
- 250 kbps data rate
- Supported by MoteWorks™ wireless sensor network platform for reliable, ad-hoc mesh networking
- Plug and play with ACEINNA's sensor boards, data acquisition boards, gateways, and software

MoteWorks™ enables the development of custom sensor applications and is specifically optimized for low-power, battery-operated networks. MoteWorks is based on the open-source TinyOS operating system and provides reliable, ad-hoc mesh networking, over-the-air-programming capabilities, ACEINNA development tools, server middleware for enterprise network integration and client user interface for analysis and a configuration.

### Processor & Radio Platform (MPR2400CB)

The MPR2400 is based on the Atmel ATmega128L. The ATmega128L is a low-power microcontroller which runs MoteWorks from its internal flash memory. A single processor board (MPR2400) can be configured to run your sensor application/processing and the network/radio communications stack simultaneously. The 51-pin expansion connector supports Analog Inputs, Digital I/O, I2C, SPI and UART interfaces. These interfaces make it easy to connect to a wide variety of external peripherals. The MICAz (MPR2400) IEEE 802.15.4 radio offers both high speed (250 kbps) and hardware security (AES-128).

### Sensor Boards

ACEINNA offers a variety of sensor and data acquisition boards for the MICAz Mote. All of these boards connect to the MICAz via the standard 51-pin expansion connector. Custom sensor and data acquisition boards are also available. Please contact ACEINNA for additional information.



Processor/Radio Board	MPR2400CB	Remarks
<b>Processor Performance</b>		
Program Flash Memory	128K bytes	
Measurement (Serial) Flash	512K bytes	> 100,000 Measurements
Configuration EEPROM	4K bytes	
Serial Communications	UART	0-3V transmission levels
Analog to Digital Converter	10 bit ADC	8 channel, 0-3V input
Other Interfaces	Digital I/O,I2C,SPI	
Current Draw	8 mA	Active mode
	< 15 $\mu$ A	Sleep mode
<b>RF Transceiver</b>		
Frequency band <sup>1</sup>	2400 MHz to 2483.5 MHz	ISM band, programmable in 1 MHz steps
Transmit (TX) data rate	250 kbps	
RF power	-24 dBm to 0 dBm	
Receive Sensitivity	-90 dBm (min), -94 dBm (typ)	
Adjacent channel rejection	47 dB	+ 5 MHz channel spacing
	38 dB	- 5 MHz channel spacing
Outdoor Range	75 m to 100 m	1/2 wave dipole antenna, LOS
Indoor Range	20 m to 30 m	1/2 wave dipole antenna
Current Draw	19.7 mA	Receive mode
	11 mA	TX, -10 dBm
	14 mA	TX, -5 dBm
	17.4 mA	TX, 0 dBm
	20 $\mu$ A	Idle mode, voltage regular on
	1 $\mu$ A	Sleep mode, voltage regulator off
<b>Electromechanical</b>		
Battery	2X AA batteries	Not Include n Pack
External Power	2.7 V - 3.3 V	Molex connector provided
User Interface	3 LEDs	Red, green and yellow
Size (in)	2.25 x 1.25 x 0.25	Excluding battery pack
(mm)	58 x 32 x 7	Excluding battery pack
Weight (oz)	0.7	Excluding batteries
(grams)	18	Excluding batteries
Expansion Connector	51-pin	All major I/O signals

**Notes**

<sup>1</sup>5MHz steps for compliance with IEEE 802.15.4/D18-2003.

Specifications subject to change without notice



MIB520CB Mote Interface Board

## Base Station

A base station allows the aggregation of sensor network data onto a PC or other computer platform. Any MICAz Mote can function as base station when it is connected to a standard PC interface or gateway board. The MIB510 or MIB520 provides a serial/USB interface for both programming and data communications. ACEINNA also offers a stand-alone gateway solution, the MIB600 for TCP/IP-based Ethernet networks.

### Ordering Information

Model	Description
MPR2400CB	2.4 GHz MICAz Processor/Radio Board
WSN-START2400CB	2.4 GHz MICAz Starter Kit
WSN-PRO2400CB	2.4 GHz MICAz Professional Kit