



High Performance Bi-Directional Digital MEMS Gas Flow Sensor

MFC2000 Series

FEATURES

- Bi-directional flow (± 30 or ± 70 SLM)
- High dynamic range
- $\pm 3\%$ m.v. accuracy
- $\pm 0.8\%$ m.v. repeatability
- Low power consumption
- Fast response time
- Single 2.7 - 5.5Vdc power supply
- Digital I²C output
- Standard push-in fitting sizes
- Custom fluid connector available
- Temperature compensated
- Highly configurable firmware
- Easy-to-use PC-based GUI
- RoHS and WEEE compliant

APPLICATIONS

- Medical gas flow measurement and control
- Industrial gas flow measurement and control
- Consumer products

DESCRIPTION

MFC2000 series is a new gas flow sensing module platform based on ACEINNA's proprietary CMOS technology for thermal mass flow sensing. It can measure up to 70 SLM bi-directional flow rate with +/- 3.0% accuracy.

The sensing element is monolithically integrated with CMOS signal processing circuitry and embedded software capable of converting gas flow rates to a digital output with very high repeatability. The module has very low operating power consumption (< 5 mA) and a low power consumption sleep mode (<100 μ A) for optimal power management in portable applications. The MFC2000 series is

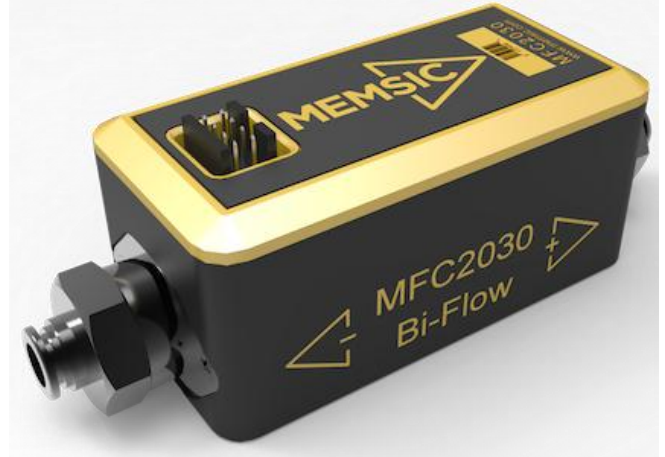

MFC2030 ± 30 SLM version.

externally powered, up to 5.5V (3.3V typ.). I²C digital output is standard. Other output available upon request.

The MFC2000 series includes firmware that is highly configurable, offering the user a variety of settings that can be tailored to specific applications. This includes data output type, calibration settings, measurement modes, and power consumption. A user-friendly PC-based application offers the user a variety of data collection options, including real-time graphical display. Mechanically, the unit includes fittings that can accept a variety of standard inlet tube sizes.

MFC2000 series is a true thermal mass flow sensing module, and can easily be configured to suit a variety of applications, from medical flow to industrial processing. Customized versions, including customer specific bulk channel and mounting options are available.

For more information, please contact ACEINNA at sales@airmarsensor.com

©ACEINNA, Inc.

Information furnished by ACEINNA is believed to be accurate and reliable. However, no

responsibility is assumed by ACEINNA for its use, or for any infringements of patents or other rights of third parties, which may result from its use. No license is granted by implication or otherwise under any patent or patent rights of ACEINNA.

www.airmarsensor.com

SENSOR CHARACTERISTICS

(Measurements performed with air at 23°C temperature, 1 Atm pressure, 50% RH, at 5.0V DC power supply, unless otherwise specified). Calibration conditions for standard liters per minute slm: 20°C, 1013mbar.

Parameter	Condition	30 SLM	70 SLM	Unit
Measurement Range	Straight/Manifold Mounting	+/- 30	+/- 70	SLM
Flow Direction		Bi-directional		N/A
Supply DC Voltage (VDD)		2.7 – 5.5		Vdc
Interface Voltage ¹ (VDDIO)	(See note 1)	2.7 – 3.0		V
Output Range	I2C Mode ²	0 – 65,535		LSB
Operating Temperature		(20) – 80		°C
Calibrated Temperature		0 – 50		°C
Storage Temperature		(40) – 85		°C
Relative Humidity	non-condensing	0 – 95		%
Supply Current ³	Operating mode	5		mA
	Sleep mode	100		µA
Accuracy ⁴	$0.01Q_{max} \leq Q < Q_{max}$	3.0		% m.v.
	$Q < 0.01Q_{max}$	0.03		% F.S.
Repeatability ⁵	ODR = 100Hz	$0.1Q_{max} \leq Q \leq Q_{max}$	0.8	% m.v.
		$Q < 0.1Q_{max}$	0.08	% F.S.
	ODR = 10Hz	$0.1Q_{max} \leq Q \leq Q_{max}$	0.3	% m.v.
		$Q < 0.1Q_{max}$	0.03	% F.S.
RMS Noise at Zero Flow	ODR = 100Hz	25		sccm
	ODR = 10Hz	8		sccm
Offset Shift w/Temp.	0 - 50°C	2		SCCM/°C
Total Error Band ⁴	0 - 50°C, $0.1Q_{max} \leq Q \leq Q_{max}$	3.5		% m.v.
Pressure Drop	Q_{max}	4	18	mbar
Sample Rate		10		msec
Orientation Sensitivity		< 60		sccm
Wake Time	Wake up from sleep mode	40		msec
Working Pressure		0 - 8		Bar
Module Weight	Includes aluminum inserts	< 100		g
Wetted Material	Si, SiO ₂ , Si ₃ N ₄ , Aluminum, PPSU, Stainless steel, Viton, Nitrile rubber, Aluminum alloy 3003, Epoxy, Silicone			

Note 1: VDDIO is generated internally and should be used to set the logic high voltage for I²C interface. VDDIO can supply a current up to 100 mA.

Note 2: Use two's complement as binary signed number representation.

Note 3: Power consumption can be optimized using "Power-Cycle" configuration to program the wake and sleep duration.

Note 4: Accuracy is defined as the sum of all dc errors (linearity) at 23°C. Error Band is defined as the sum of accuracy and offset/span due to temperature. Both are measured after factory calibration, using internal averaging (100x) to eliminate errors due to noise. If the end application requires a high Output Data Rate (ODR), and cannot benefit from averaging, the total RMS error of any given measurement can be calculated by adding the repeatability specification.

Note 5: Repeatability is defined as standard deviation divided by mean flow (% m.v.), or standard deviation divided by F.S. (% F.S.). Average/ODR is programmable.

ABSOLUTE MAXIMUM RATINGS*

- Supply Voltage (V_{DD}) 2.7 to +5.5V
- Storage Temperature-40°C to +85°C
- Pressure0 - 8 Bar Gauge
- Shock 10g, 0.5ms
- Vibration 1g, 5 to 200 Hz
- ESD 4kV/8kV (contact/air discharge)

Note: Stresses above those listed under Absolute Maximum Ratings may cause permanent damage to the device. This is a stress rating only; the functional operation of the device at these or any other conditions above those indicated in the operational sections of this specification is not implied. Exposure to absolute maximum rating conditions for extended periods may affect the device’s reliability.

CONFIGURATION AND MARKING

Pinout Configuration:

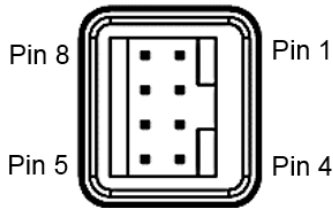

MFC2030 pin configuration.

Pin	Name	Description
1	VDD	Power Supply
2	VDDIO	I/O Voltage Reference
3	SCL	Serial Clock Line for I ² C bus
4	SDA	Serial Data Line for I ² C bus
5	GND	Connect to Ground
6	GND	Connect to Ground
7	GND	Connect to Ground
8	NC	Not Connected

Marking Illustration:

- Line 1: The arrow sign of ACEINNA Logo denotes the positive direction of flow
- Line 2: Model name
- Line 3: Barcode (shown below as a space)
- Line 4: Lot number



THEORY OF OPERATION

The flow rate is detected by the MEMS thermal mass flow sensor. The sensor chip, produced in ACEINNA proprietary CMOS compatible technology, is composed of a central heater source (micro heater) and two temperature sensors (thermopiles), which are placed symmetrically upstream and downstream of the micro-heater. If no gas flows over the sensor surface, the symmetric thermopiles measure the same rise in temperature, resulting in the same output voltage of the two thermopiles. If a non-zero gas flows from the inlet to the outlet of the meter, the velocity of a fully-developed laminar air flow unbalances the temperature profile around the heater and heat is transferred from upstream thermopiles to the downstream thermopiles, causing a change in the voltages of the thermopiles. Larger gas flow rates result in larger asymmetry in the profile.

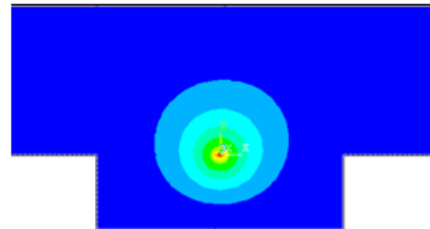

Zero gas flow.

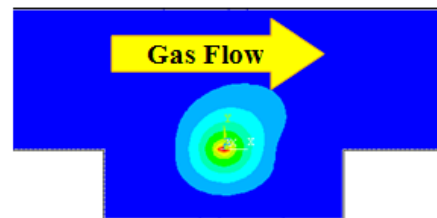

Non-zero gas flow.

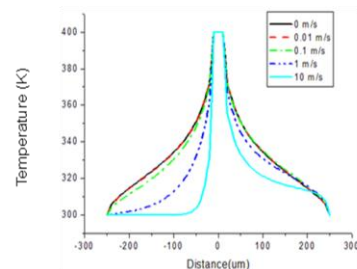

Temp. profiles vs. distances/gas velocities.

PACKAGE DRAWING

The ACEINNA MFC2000 series Mass Flow Meter is mounted in chemically inert filled PPSU housing (available in other material, see “Order Information”). The physical dimensions, mounting information and pin layout are provided below. A push-in tube fitting or a PPSU flange (manifold mounting) is provided on inlet and outlet sides of the module for flow connection. For electrical connection, an 8-pin male header (FCI 69168-108HLF) is provided on the top side of the module for I²C interface connection. The recommended mechanical/electrical connectors are shown as follows. The unit can be printed circuit board mounted is needed.

Recommended Connector		Example
Flow Fitting	Push-in connector included	See “Ordering Information”
Electrical	8 pin crimp to wire housing (2.54mm pitch, 2 rows, 2.54mm row space)	FCI 65846-016LF

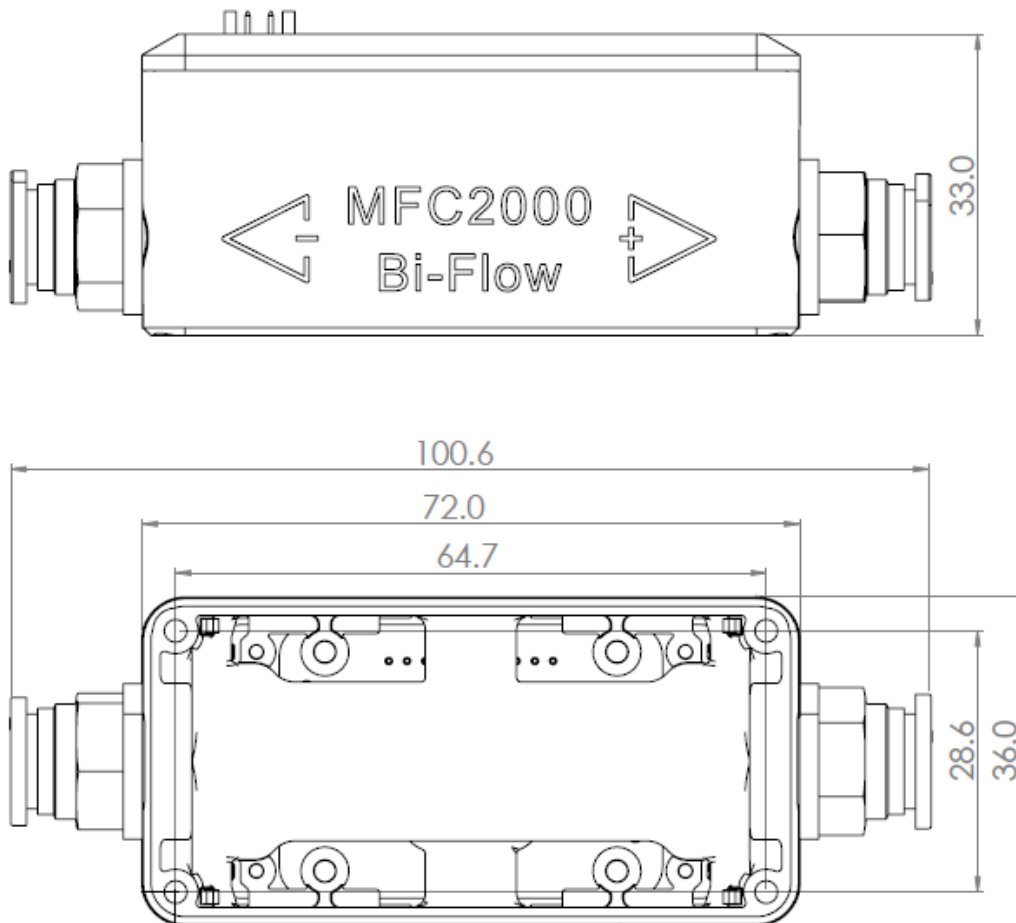

MFC2000 module mechanical dimensions (in mm).

MFC2030 I2C Communication

MFC2030 Pin Configuration

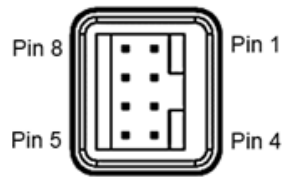

Figure.1 MFC2030 Pin Configuration

Table.1 MFC2030 Pin Configuration

Pin	Name	Description
1	VDD	Power Supply
2		NA
3	SCL	Serial Clock Line for I ² C bus
4	SDA	Serial Data Line for I ² C bus
5	GND	Connect to Ground
6	GND	Connect to Ground
7	GND	Connect to Ground
8		NA

2. Hardware Connection

SCL and SDA pins must be connected with around 4.7k Ohm pull-up resistors to VDD, recommending voltage is 5V +/- 10%.

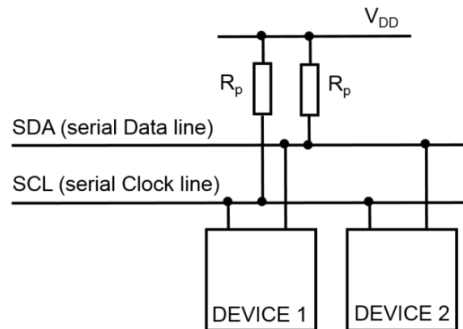

Figure.2 Pull-up Resistors Connection

3. I2C Read and Write Timing

I2C communication using standard I2C protocol, as shown below, recommending SCL frequency about 100kHz.

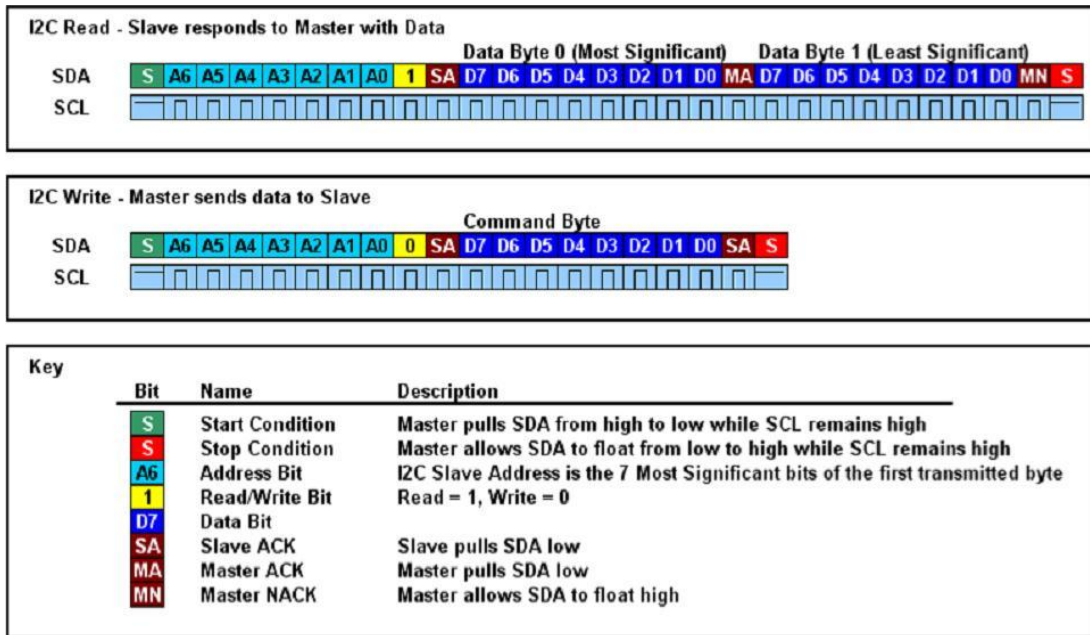

Figure.3 MFC2030 I2C Communication Timing Example

Note: Timing example above shows slave responds to master with 2 bytes data and master sends 1 byte command to slave respectively.

4. MFC2030's Register Map

Table.2 MFC2030 Register Map

Register Address	Name	Description	Read	Write
0	Flow Rate	MSB	Yes	N/A
0		LSB	Yes	N/A
1	Temperature	MSB	Yes	N/A
1		LSB	Yes	N/A

5. MFC2030's Reading Operation

MFC2030 will update its registers every 10 ms interval, so the master can read out data from MFC2030's register 0, 1 every 10ms interval.

MFC2030 works as slave, in the first byte it receives, it must include 7-bit slave address(0x31), and a bit which is either write bit(0) or read bit(1).

To read data from register, master must do writing operation first, which means master must write 1-byte register address (it specify which address master starts to read from) to slave first, then master do reading operation. There must be at least 1 ms delay between writing and reading operations.

For example, to read out the data in register 0, there are 2 steps as the following:

(1) Master Writes Register Address

Master should write the register address 0x00 into slave, specifying that master will read from register 0 of slave. As Table.3 shown, the first byte master sends includes a 7-bit address 0x31 and a write bit 0, the second byte it sends is register address 0x00.

Table.3 The Data Master Sends while Master Writes Register Address to Slave

Slave address + Write bit	Register Address
$0x62 = (0x31 \ll 1) + 0$	0x00

(2) Master Reads Data from Slave

As Table.4 below shown, after slave receives a 7-bit address 0x31 and a read bit 1 from master, if slave's SCL pin receives pulses of 2 bytes data generated by master, accordingly the slave's SDA pin will return 2 bytes flow data as Table.5 shown.

Table.4 The Data and Pulses Master Sends while Master Reads Data from Slave

Slave Address + Read bit	Pluses of 2 Bytes
0x62 = (0x31<<1) + 1	High Byte, Low Byte

Table.5 The Data Slave Returns while Master Reads Data from Slave

High Byte	Low Byte
-----------	----------

Notes:

- a. '0x' means that the data mentioned in this note is hexadecimal.
- b. '<<' means data shifts left.
- c. Slave returns the high byte first, then the low byte.
- d. If you want to read temperature data from register 1, just change the register address as 0x01 as step (1), and then finish the step (2).
- e. There must be at least 10ms time delay between any two register reading operations, otherwise, the data will not be updated.
- f. Any other registers are not available for customer, if you write any data to any register we didn't mention in this note, it probably cause MFC2030's firmware broken!

6. Data Format

The output data of register 0 is 16-bit signed integer data, which is from -32000 to 32000 sccm.

The output data of register 1 is 16-bit signed integer data, which needs to be divided by 10 to get the measured temperature (Unit: Celsius Degree).

ORDERING INFORMATION

Options	Ranges		Calibration		Housing Material		Tube OD*	
MFC	2030	30 SLM	B	Bi-Directional	P	PPSU	1	6 mm
	2070	70 SLM	U	Uni-Directional				
Gas	Gas		I2C Address					
	N	Air/N ₂	1	0x31 (preferred)				
	X	O ₂	2	0x21				
	C	CO ₂	3	0x23				
	R	Ar	4	0x33				
	M	CH ₄	5	0x35				
			6	0x41				
			7	0x43				
			8	0x45				

* Additional Mechanical Interface available for OEM applications.

Revision Log

Date	Author	Revision	Changes
July 14, 2017	O.Silpachai	1.05	Initial Release
September 21, 2017	O.Silpachai	1.10	Removed Analog (PWM) Output, Eliminate Tube OD for 1/4 inch, 10 mm, 3/8 inch, and manifold mount.

www.airmarsensor.com